

# AUTOMOULD

August 2019

# *Precision Plastic Injection Moulders*

- Established in 1979.
- 2018 Consolidated Smiths Plastics & Automould under one Roof.
- 3 Manufacturing Sites (New Germany, Westmead, East London.)
- 546 Employees
- Specialize in Injection Moulded Automotive Parts and Finishes
- Leaders in Injection Moulding Technologies –
  - Chrome Plating on Plastic
  - Gas Assisted Injection Moulding
  - 2K Injection Moulding
  - Painting – Body Colour and Soft Touch
  - Vibration and Hot Plate Welding



# Achievements

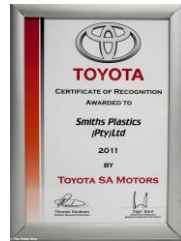

- 2005 Toyota Supplier of the Year
- 2009 VWSA Interior Supplier of the Year
- 2015 Awarded TSA Co-Operation Award
- 2015 Awarded Certificate of Recognition for New Hilux/Fortuner Project Management
- 2015 Awarded Recognition Certificate for assistance to Toyota during Earthquake in Japan and Floods in Thailand

## *Our Factories – New Germany*



- Head Office – Admin, Marketing, Purchasing, Engineering, HR
- 410 Employees
- 34 Machines : 50T – 2000T
- 2 x Chrome Plating Plants
- Paint Plant
- Assembly
- Engineering : Quality & Process
- Metrology : 3D Scanning, CMM
- Toolroom



## *Our Factories – Westmead*



- 82 Employees
- 13 Machines : 50T – 650T
- Assembly
- Painting : Non Automotive
- Printing : Silk Screen, Pad Printing
- Toolroom





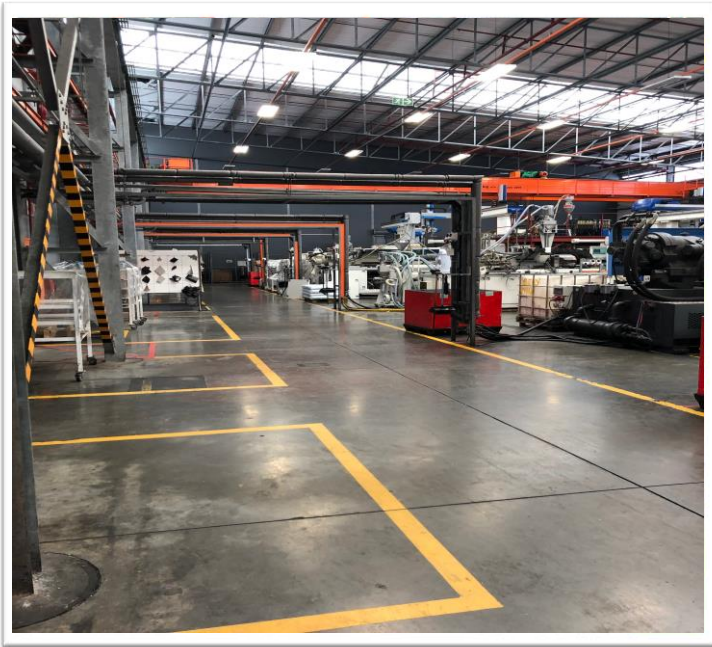



## *Our Factories – East London*



- 54 Employees
- 8 Machines : 600T – 1800T
- 1600T & 1800T 2K Side Injection
- 1000T High Precision thin wall LGF
- Toolroom



# Our Customers

REGION: EASTERN CAPE			
Customer	Segment	Tier 1	Tier 2
 Mercedes-Benz	OE		✓
	OE		✓
	OE		✓
	OE		✓
	OE		✓
	OE & Aftermarket	✓	✓
	OE	✓	

REGION: GAUTENG			
Customer	Segment	Tier 1	Tier 2
	OE		✓
	OE		✓
	OE		✓
	OE		✓
	OE & Aftermarket	✓	
	OE	✓	

REGION: KZN			
Customer	Segment	Tier 1	Tier 2
 TOYOTA	OE & Aftermarket	✓	✓
	OE & Aftermarket		✓
	OE		✓
	Aftermarket		✓
	NON - OE	✓	

# Our Technical Partners

- Kanto Kasei – Chrome Plating
- Aisin Seiki – Door Handles, Caps & Frames
- Toyota Gosei – Wheel Ornaments
- Murakami – Outer Mirrors
- Montaplast – Large 2K & Hot Plate Welding



© Barry Coleman

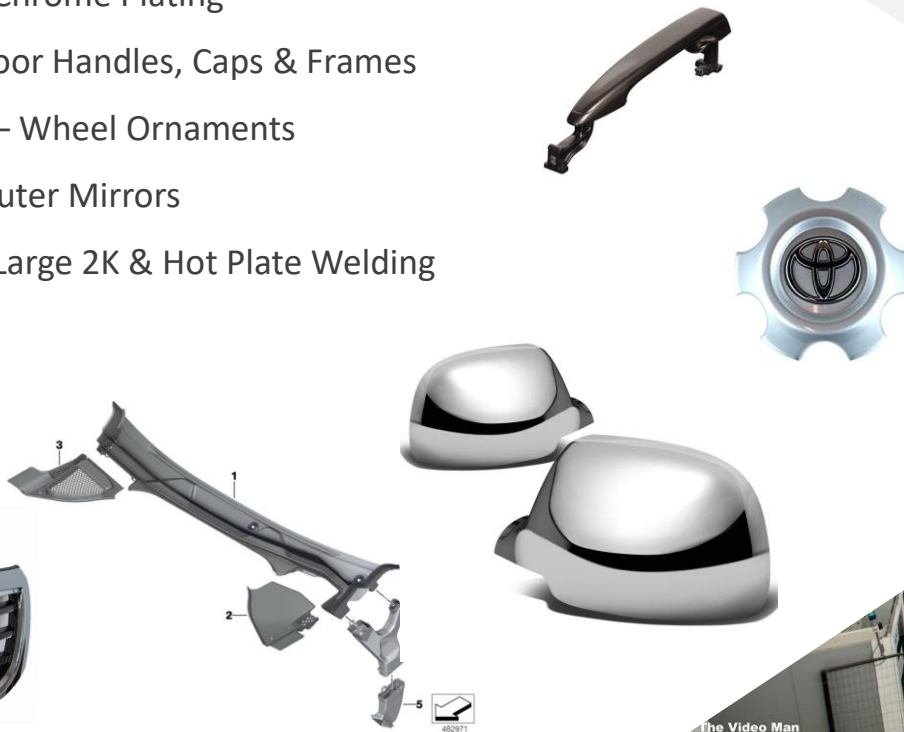

482971

The Video Man





## *Our Products - Interior*



- ABC Pillars
- Door Modules
- Dash Hang on Parts
- Inside Door Handles
- Parcel Shelves
- Scuff Plates
- Seat Trim
- Roof Lining Accessories



## *Our Products - Exterior & Under Bonnet*



- Bumper Trim
- Door Handles
- Front Grills
- Fender Aprons
- Water Management Systems
- HVAC Casings
- Radiator Tanks
- Water Reservoirs
- Cam Covers

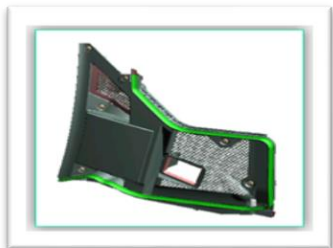

## *Our Products - Non Automotive*



- Packaging Solutions : ETAP Bin
- Appliance Industry
- Electronics Industry
- Emergency Lights

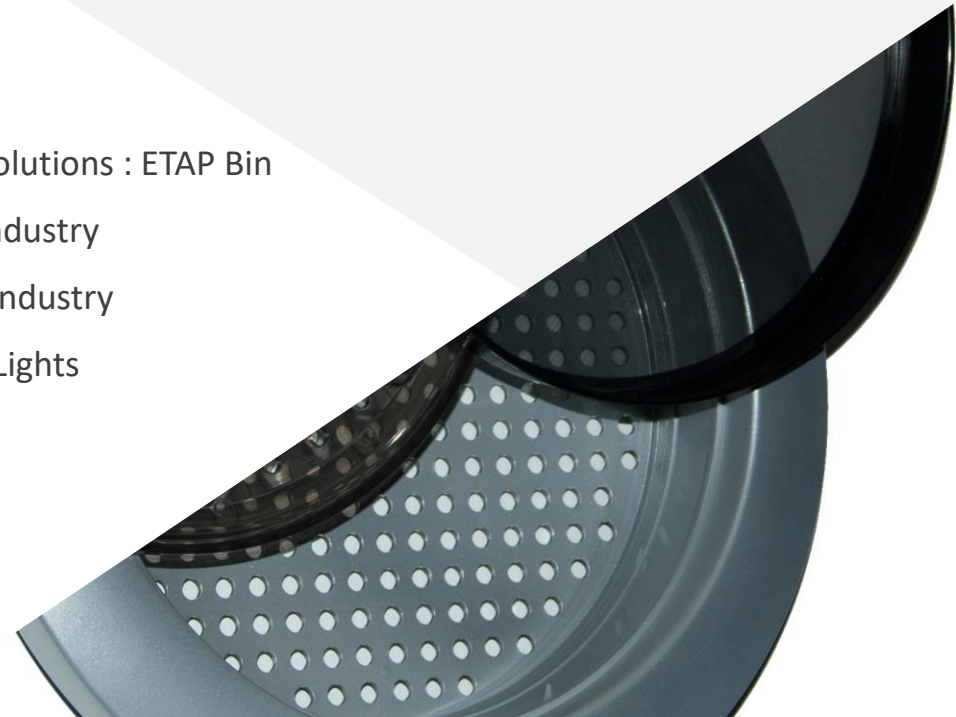

# Certifications

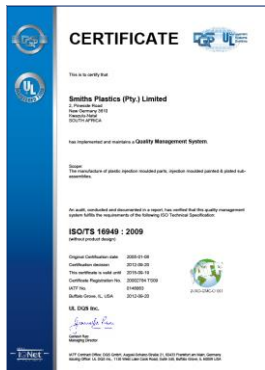

- BBBEE Level 4 (New Codes)
- IATF 16949
- ISO 14001
- ISO 9001
- ISO 18001
- ISO 50001 – Q3 2019
- VDA 6.2



# Contacts

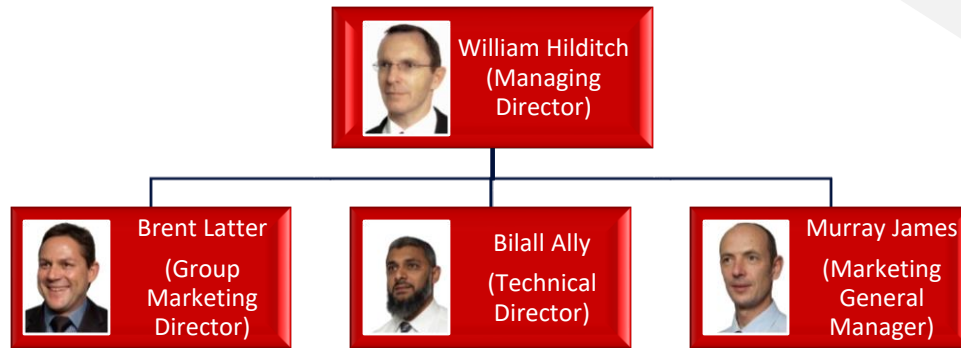

Name	Designation	Contact Number	Email Address
William Hilditch	Managing Director	+27 31 7194601	William.hilditch@smithsplastics.co.za
Brent Letter	Group Marketing Director	+27 31 7194772	Brent@automould.co.za
Bilall Ally	Technical Director	+27 31 7194777	Bilall.ally@smithsplastics.co.za
Murray James	GM – Marketing	+27 31 7194610	Murrayj@Automould.co.za



## *Safety – Plant Tour*

**! SAFETY FIRST !**



- Visitors are requested to wear personal protective equipment where required.
- Visitors are requested to stay with their Automould host at all times.
- Visitors are requested to remain in designated walkways at all times.
- Visitors are requested to be alert for moving traffic, forklifts, overhead cranes and tow-motors.
- Visitors are requested not to approach any machinery during their visit
- In case of Emergency, please stay with your host who will lead you to the Assembly point in the Production Car Park





# **AUTOMOULD**

Thank you